

# RTA 800 and RTC 800

4189350089-G

Rudder angle transmitters

**Installation instructions**

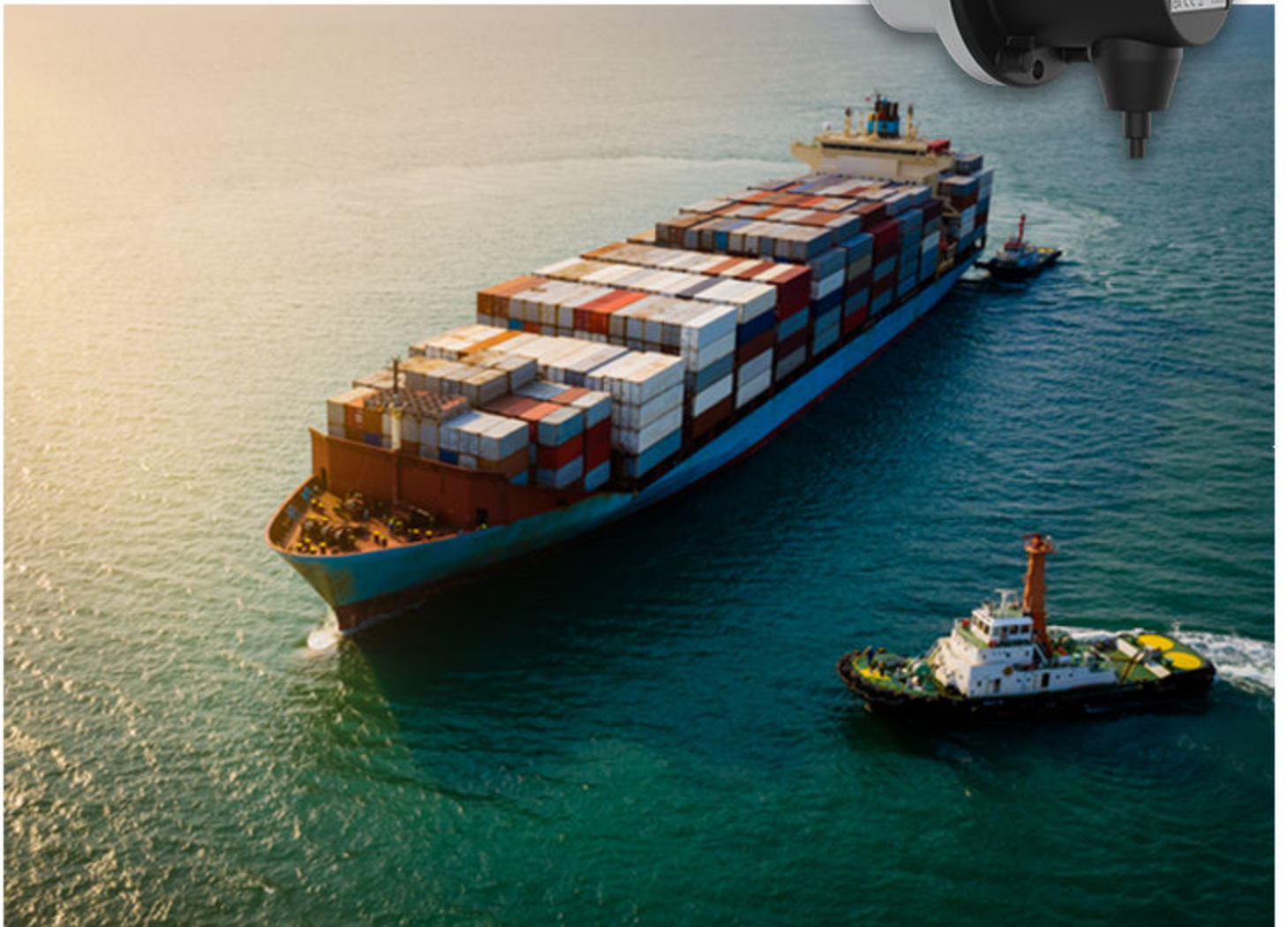

<b>1. About the installation instructions</b>	
1.1 Symbols and notation.....	<b>3</b>
1.2 Intended users of the Installation instructions.....	<b>3</b>
1.3 Warnings and safety.....	<b>4</b>
1.4 Legal information.....	<b>4</b>
<b>2. Mount the equipment</b>	
2.1 Location.....	<b>5</b>
2.2 Tools.....	<b>5</b>
2.3 Materials.....	<b>5</b>
2.4 Mounting.....	<b>6</b>
2.4.1 Dimensions.....	<b>6</b>
2.4.2 Mounting the transmitter.....	<b>8</b>
<b>3. Wiring the equipment</b>	
3.1 Terminal connections.....	<b>10</b>
3.1.1 Rudder transmitter.....	<b>10</b>
3.1.2 XL.....	<b>10</b>
3.2 Typical wiring.....	<b>11</b>
3.2.1 Analogue rudder transmitter and XL.....	<b>11</b>
3.2.2 CAN rudder transmitter and XL (sCAN).....	<b>13</b>
3.3 Shielding and grounding of CAN bus cables.....	<b>13</b>
3.4 Cable limitations.....	<b>13</b>
<b>4. Calibrate the equipment</b>	
4.1 Analogue rudder transmitter .....	<b>15</b>
4.2 CAN rudder transmitter.....	<b>20</b>
4.2.1 Synchronise XL indicators over CAN.....	<b>22</b>
<b>5. End-of-life</b>	
5.1 Disposal of waste electrical and electronic equipment.....	<b>23</b>

# 1. About the installation instructions

## 1.1 Symbols and notation

### Symbols for general notes

**NOTE** This shows general information.



**More information**

This shows where you can find more information.



**Example**

This shows an example.



**How to ...**

This shows a link to a video for help and guidance.

### Symbols for hazard statements



**DANGER!**



**This shows dangerous situations.**

If the guidelines are not followed, these situations will result in death, serious personal injury, and equipment damage or destruction.



**WARNING**



**This shows potentially dangerous situations.**

If the guidelines are not followed, these situations could result in death, serious personal injury, and equipment damage or destruction.



**CAUTION**



**This shows low level risk situation.**

If the guidelines are not followed, these situations could result in minor or moderate injury.

**NOTICE**



**This shows an important notice**

Make sure to read this information.

## 1.2 Intended users of the Installation instructions

The Installation instructions are primarily intended for the people who mount and wire up the rudder transmitter. Designers may find it useful to refer to the Installation instructions, when developing the system's wiring diagrams, and operators may find it useful to refer to the Installation instructions while troubleshooting.

## 1.3 Warnings and safety

### Safety during installation and operation

When you install and operate the equipment, you may have to work with dangerous currents and voltages. The installation must only be carried out by authorised personnel who understand the risks involved in working with electrical equipment.



**DANGER!**



#### **Hazardous live currents and voltages**

Do not touch any terminals, especially the AC measurement inputs or any relay terminals, as this could lead to injury or death.

### Factory settings

The equipment is delivered pre-programmed from the factory with a set of default settings. These settings are based on typical values and may not be correct for your system. You must therefore check all parameters before using the equipment.

## 1.4 Legal information

### Trademarks

*DEIF* and the DEIF logo are trademarks of DEIF A/S.

*Adobe*<sup>®</sup>, *Acrobat*<sup>®</sup>, and *Reader*<sup>®</sup> are either registered trademarks or trademarks of Adobe Systems Incorporated in the United States and/or other countries.

*CANopen*<sup>®</sup> is a registered community trademark of CAN in Automation e.V. (CiA).

*SAE J1939*<sup>®</sup> is a registered trademark of SAE International<sup>®</sup>.

*Google*<sup>®</sup> and *Google Chrome*<sup>®</sup> are registered trademarks of Google LLC.

*Modbus*<sup>®</sup> is a registered trademark of Schneider Automation Inc.

*Windows*<sup>®</sup> is a registered trademark of Microsoft Corporation in the United States and other countries.

All trademarks are the properties of their respective owners.

### Warranty

#### **NOTICE**



#### **Warranty**

The rudder transmitter is not to be opened by unauthorised personnel. If opened anyway, the warranty will be lost.

### Disclaimer

DEIF A/S reserves the right to change any of the contents of this document without prior notice.

The English version of this document always contains the most recent and up-to-date information about the product. DEIF does not take responsibility for the accuracy of translations, and translations might not be updated at the same time as the English document. If there is a discrepancy, the English version prevails.

### Copyright

© Copyright DEIF A/S. All rights reserved.

## 2. Mount the equipment

### 2.1 Location

Use a bracket to mount the transmitter on a flat surface close to the rudder. Before you mount the transmitter, make sure you can mechanically connect the position shaft to the rudder with a linkage system from the mounting position. Ideally, mount the transmitter as close as possible to the rudder.

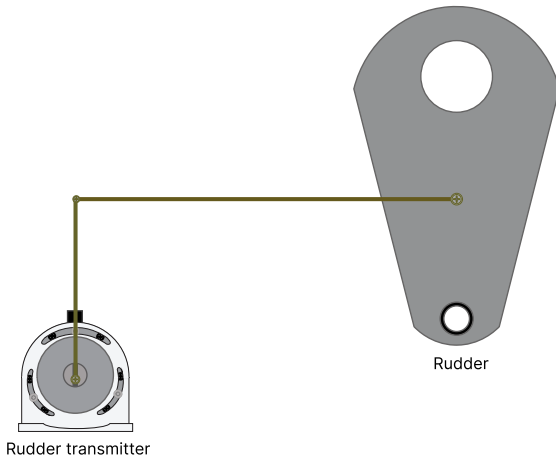

The installation environment must comply with the electrical, mechanical, and environmental specifications of the transmitter described in the Data sheet.

### 2.2 Tools

Tool	Notes
Size 5 Allen key (hex head screwdriver)	Used for the screws supplied with the bracket. These screws are used to secure the transmitter in the bracket.
Allen key or adjustable spanner *	Used to mount the bracket fasteners.
Adjustable spanner	Used to tighten the fasteners in the linkage system.
Wire stripper, pliers, and cutters	Prepare wiring and trim cable ties
Safety equipment	Personal protection, according to local standards and requirements

**NOTE** \* The tool for the bracket fasteners depends on the type of fasteners you use.

### 2.3 Materials

Material	Notes
Three hex socket head cap screws	To mount the transmitter in the bracket. Diameter is 6 mm and the length is 30 mm. Supplied with the product.
Three flat washers without chamfer	To use with the hex screws. Supplied with the product.
Three split spring lock washers with flat ends	To use with the hex screws. Supplied with the product.
Two bolts or screws	To mount the bracket. Not supplied with the product.

Material	Notes
Two flat washers	To use with the bolts or screws for the bracket.
Two split washers	To use with the bolts or screws for the bracket.
Wires and connectors	To wire the equipment.
Cable ties	To secure wiring.

## 2.4 Mounting

### 2.4.1 Dimensions

#### Dimensions without a bracket

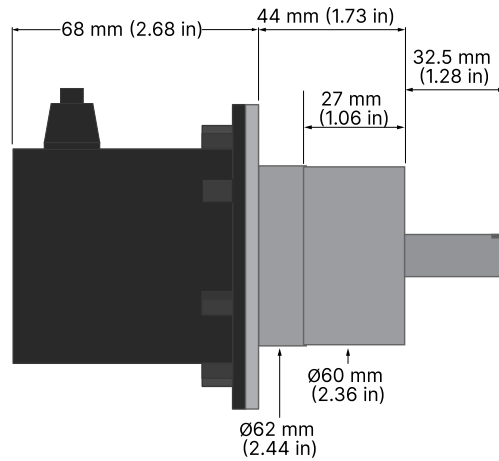
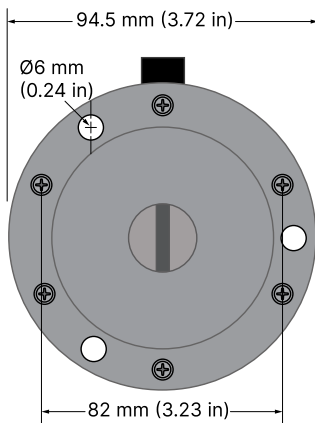
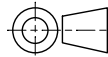
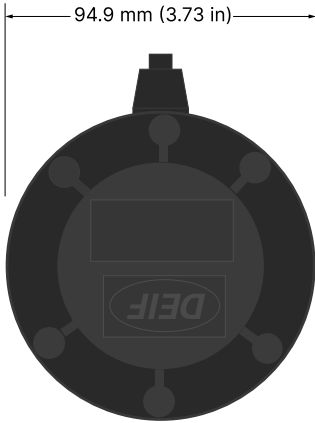

## Dimensions with the bracket from DEIF

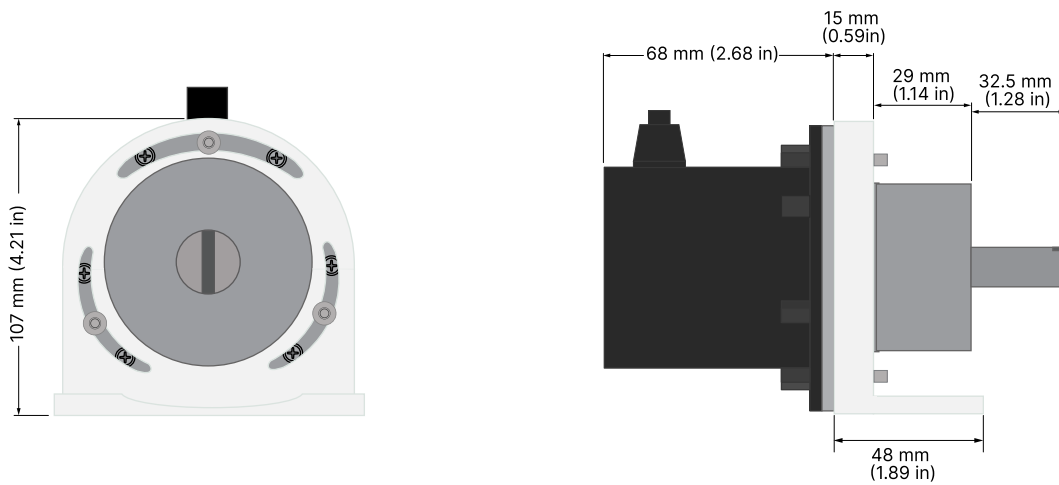
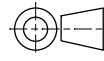

### Weight

Rudder transmitter with bracket	964 g
Rudder transmitter without bracket	653 g

**NOTE** The cable from the transmitter is 2 m 5 x 0.5 mm<sup>2</sup>.

## 2.4.2 Mounting the transmitter

Fasteners for mounting the bracket are not supplied with the transmitter. The fasteners must be able to support the weight of the transmitter and the wiring. Only the fasteners to secure the transmitter in the bracket are supplied with the product when you order a bracket from DEIF.

1.

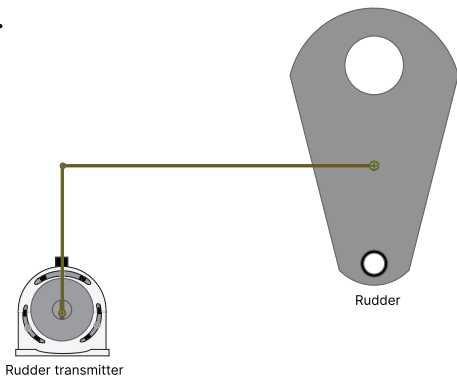

Before you start, make sure you can mechanically connect the position shaft, on the transmitter, to the rudder by a linkage system from the mounting position. Ideally, mount the transmitter as close as possible to the rudder.

2.

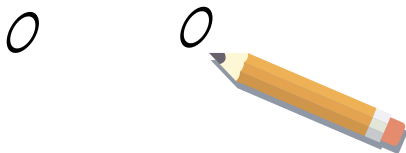

Measure and mark the mounting holes on the surface in the selected location.

3.

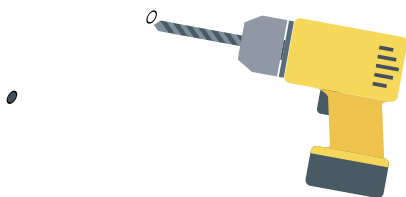

Drill and tap the holes for the bracket.

4.

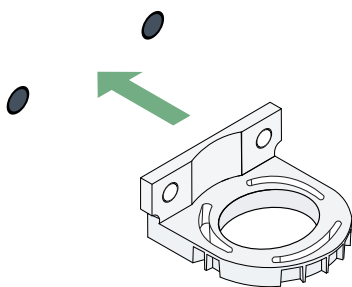

Align the bracket with holes, including washers.

5.

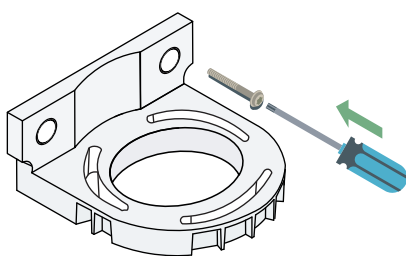

Tighten all the fasteners until the bracket is securely attached to the surface. Remember to place the washer and then the split washer on the screw or bolt before you tighten the fastener.

Do not overtighten the fasteners and damage the bracket.

6.

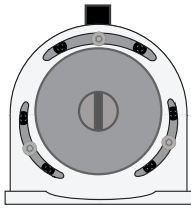

Place the transmitter in the bracket and use the supplied hex screws to secure the transmitter to the bracket. Remember to place washer and then the split washer on the screws before you tighten the fasteners.

Do not exceed the recommended torque of 3.3 Nm.

7.

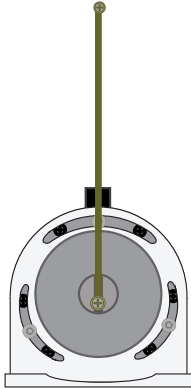

Connect a lever to the top of the position shaft on the rudder transmitter.

8.

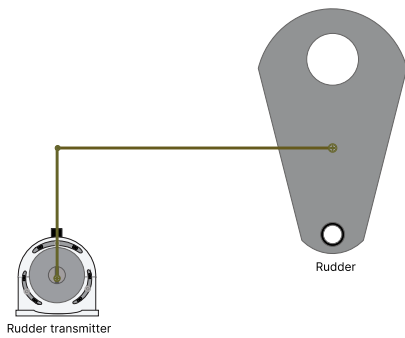

Use a connection rod to connect the lever to the rudder. Make sure the connection rod is free to pivot at either end.

## 3. Wiring the equipment

### 3.1 Terminal connections

#### 3.1.1 Rudder transmitter

##### Analogue

Wire	Function	Description
White	- V	Supply voltage
Brown	+ V	Supply voltage
Green	U <sub>out</sub> /I <sub>out</sub>	Analogue output
Yellow	DV	Data valid output
Grey	Teach	Teach input used for calibration

##### CAN

Wire	Function	Description
Grey	CAN GND	Common for CAN inputs
Brown	+ V	Supply voltage
White	- V	Supply voltage
Green	CAN High	CAN connection
Yellow	CAN Low	CAN connection

### NOTICE



#### Risk of damage to the sensors

Connect the RTA 800 and the RTC 800 correctly in accordance with the terminal connections tables.

#### 3.1.2 XL

##### Analogue input indicators

Terminal	Function	Description	Note
1	0 V	Supply voltage	Power consumption: 150 mA maximum
2	24 V	Supply voltage	
3	Input 1 (sin)	Analogue input	Input 1 and input common are used for single input. For 4 to 20 mA, input 1 is CW and input 2 is CCW. Input common is the same for input 1 and input 2.
4	Input common	Analogue input	
5	Input 2 (cos)	Analogue input	
6	Illumination +	Illumination	Dimmer input Dimmer range: 7 to 30 V DC Consumption: 30 mA maximum
7	Illumination GND	Illumination	
8	NC	Not connected	
A	Max adjustment	Analogue adjustment	Maximum and zero adjustment. Terminals are sealed by label. On 360 degree versions, A is EM selection and B is zero adjustment.
B	Zero adjustment	Analogue adjustment	

## sCAN input indicators

Terminal	Function	Description	Note
1	0 V	Supply voltage	Power consumption: 150 mA maximum
2	24 V	Supply voltage	
3	CAN 1 High	CAN input	CAN 1 line, sCAN line
4	CAN 1 Low	CAN input	
5	CAN 1 GND	CAN input	
6	Not used	Not used	Used for configuring the minimum, zero, and maximum values using an external switch (terminals 7 and 8).
7	Switch/button	CAN	
8	GND	CAN	See <b>Section 4.2</b> for how to use the switch for calibration.
9	NC	Not connected	Dimmer input Dimmer range: 7 to 30 V DC Consumption: 30 mA maximum
10	Illumination GND	Illumination	
11	Illumination +	Illumination	

## 3.2 Typical wiring

### NOTICE



#### Cable tension

Make sure you install the cable from the rudder transmitter with sufficient slack to prevent tension in the cable.

### 3.2.1 Analogue rudder transmitter and XL

#### Clockwise wiring

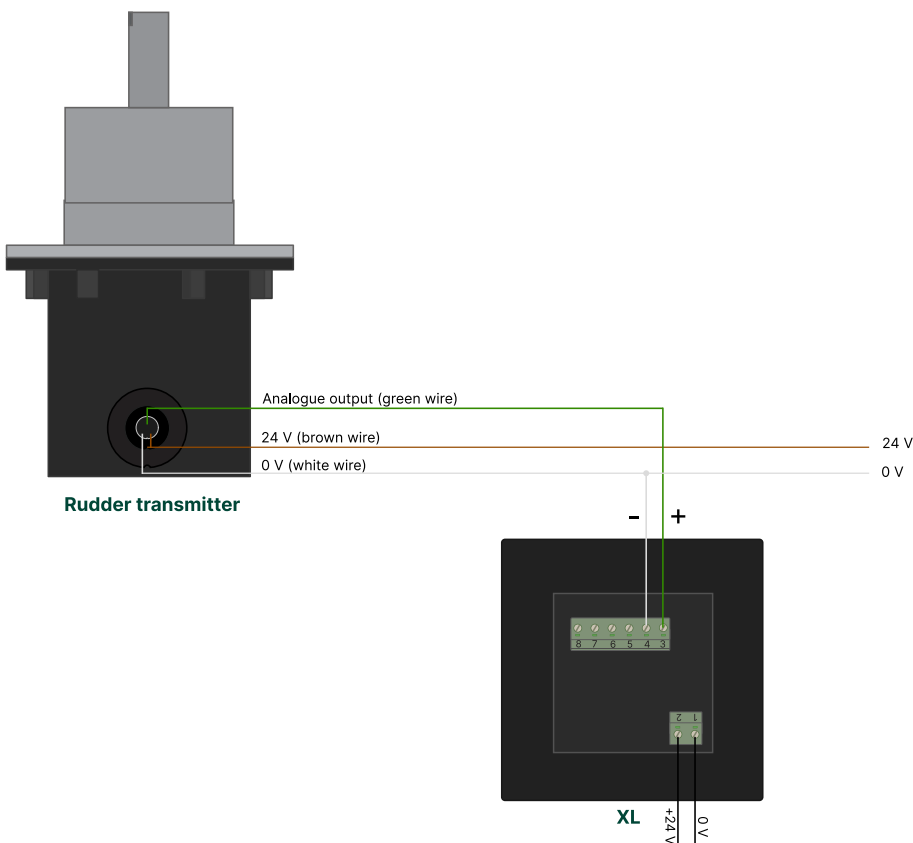

## Counterclockwise wiring

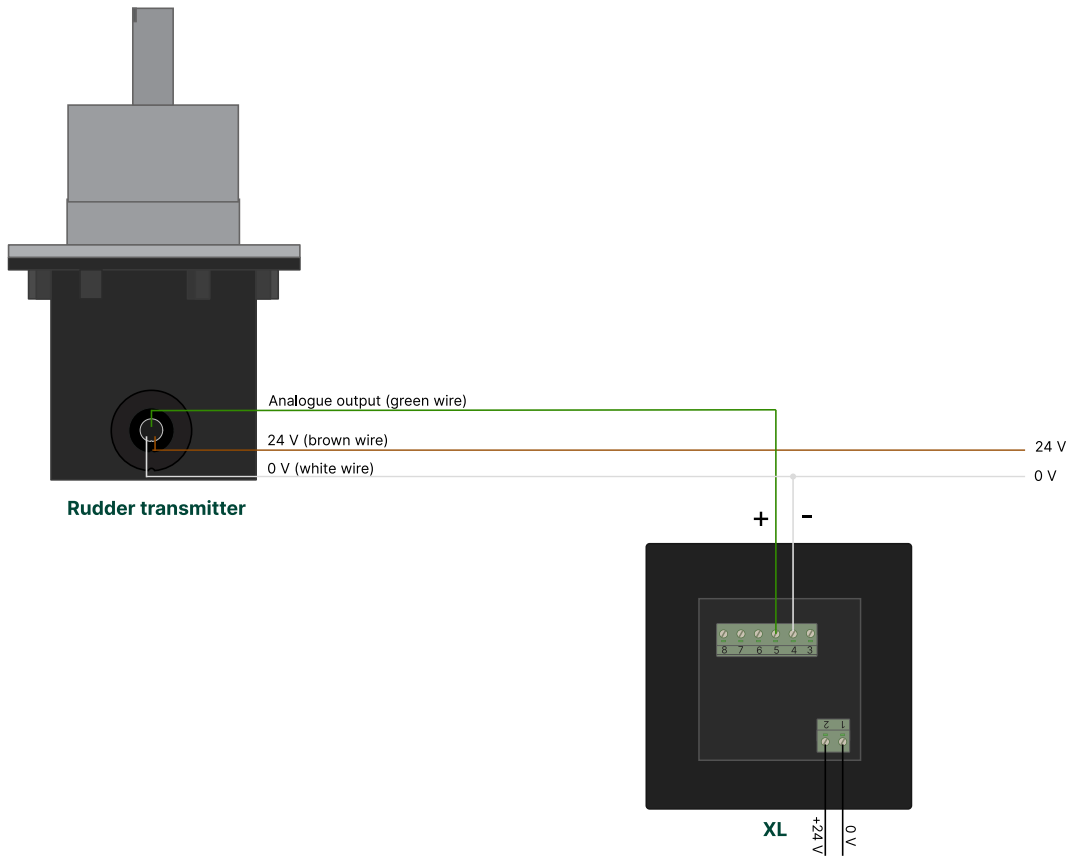

## NOTICE



### Calibration wires from the RTA 800

Make sure you insulate and terminate the calibration wires from the RTA 800 after calibrating the transmitter.

### 3.2.2 CAN rudder transmitter and XL (sCAN)

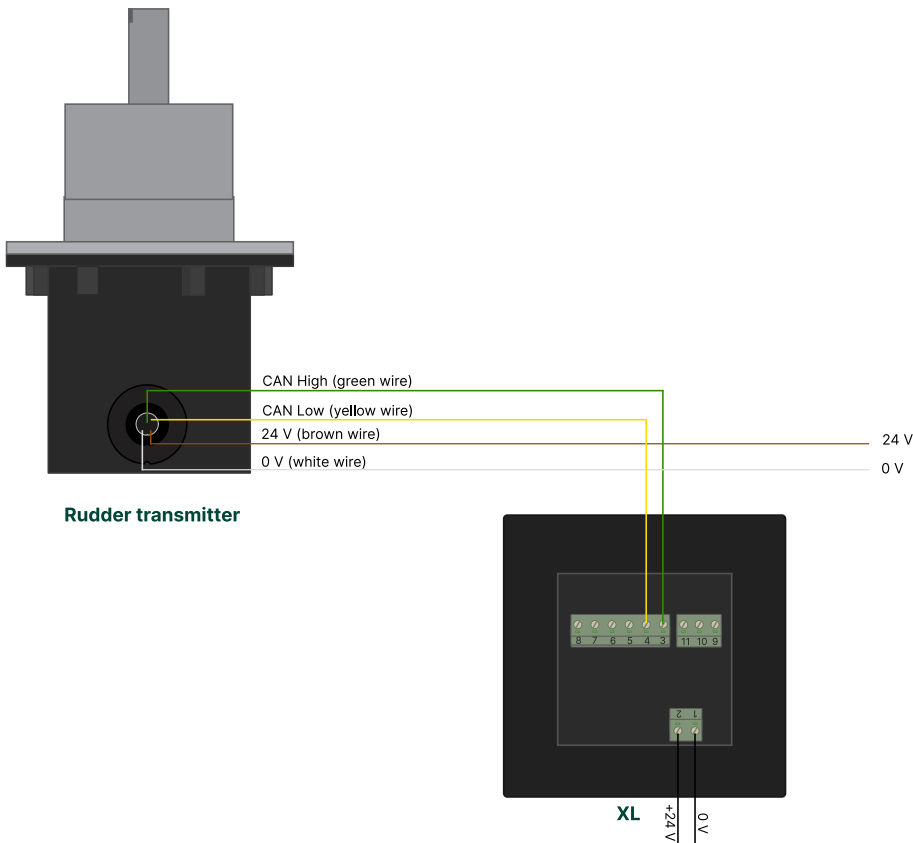

Do not connect the CAN GND wire to the XL, instead insulate the GND wire.

## 3.3 Shielding and grounding of CAN bus cables

### Cable shield

When you connect CAN cables, you must also connect the cable shields together. Do not connect the cable shield to the CAN GND terminal. CAN GND is a common terminal that must only be used if there is an extra common mode wire included in the CAN cable (the twisted pair for data and one common wire). The extra wire reduces common mode voltage between CAN devices on the bus, however this is only rarely used in marine applications.

### Grounding

DEIF recommends to only connect the shield, of the total CAN bus network, to the ground of the ship at one single location.

You must use a ground connection that is free from noise and transients produced by other devices using the same ground connection. If a good and noise-free ground connection is not available, DEIF recommends to not connect the CAN bus cable shield to ground.

**NOTE** If you use multiple ground connections on the CAN bus cable, it can create electrical noise loops disturbing the CAN bus communication.

## 3.4 Cable limitations

The cable attached to the rudder transmitter has a minimum curvature radius of 30 mm and a maximum displacement of 5° from the centre as shown in the diagram below.

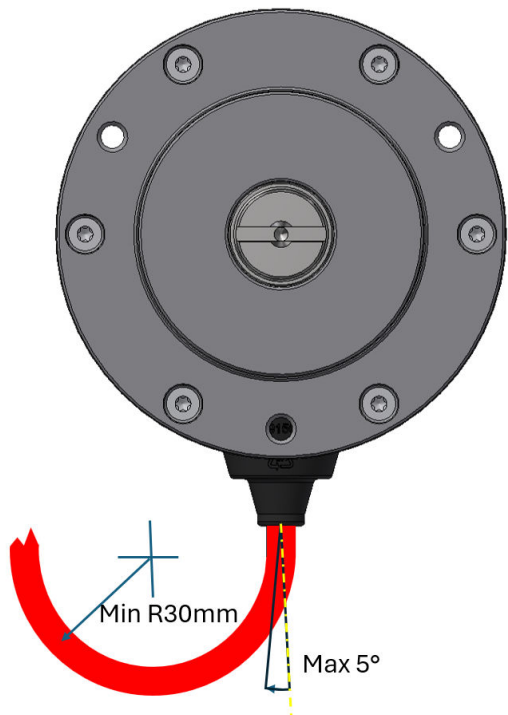

## 4. Calibrate the equipment

### 4.1 Analogue rudder transmitter

You need to calibrate the minimum and maximum angle values after installation of the rudder transmitter. This is to make sure that the port and starboard movements of the rudder are displayed correctly on the rudder indicator.

The teach input and output are used to teach the rudder transmitter its range and calibrate the physical limits of the rudder movement. The minimum angle corresponds to 4 mA and the maximum angle corresponds to 20 mA. The analogue XL is configured so that when you connect the rudder transmitter to terminals 3 and 4, the pointer deflection is clockwise. This means that the minimum rudder value is equal to 4 mA and that the maximum angle value is equal to 20 mA. The XL is not needed for the actual calibration, but used to verify that the calibration has been done correctly.

The calibration must be done within the first five minutes of switching on the power supply for the teach input.

**NOTE** The diagrams in the calibration procedure does not include the connection of the rudder transmitter to the rudder. However, the rudder transmitter in your system must be connected to the rudder before you begin the calibration process.

1.

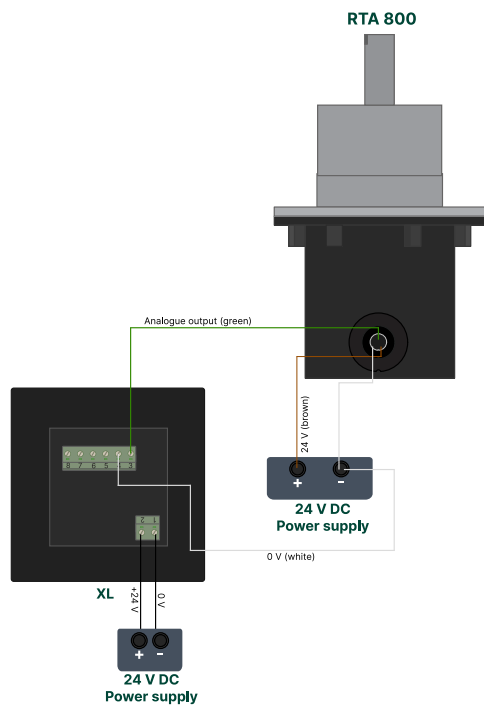

Connect the rudder transmitter to the XL as shown in the diagram.

In this example, the pointer deflection is clockwise. Use terminals 4 and 5 for counterclockwise.

2.

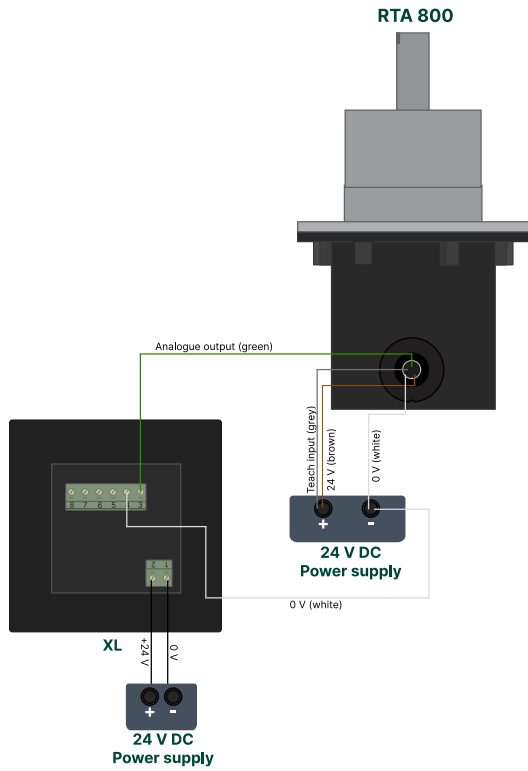

Connect the teach input (grey wire) to the plus terminal on the 24 V DC power supply used to power the RTA 800.

3.

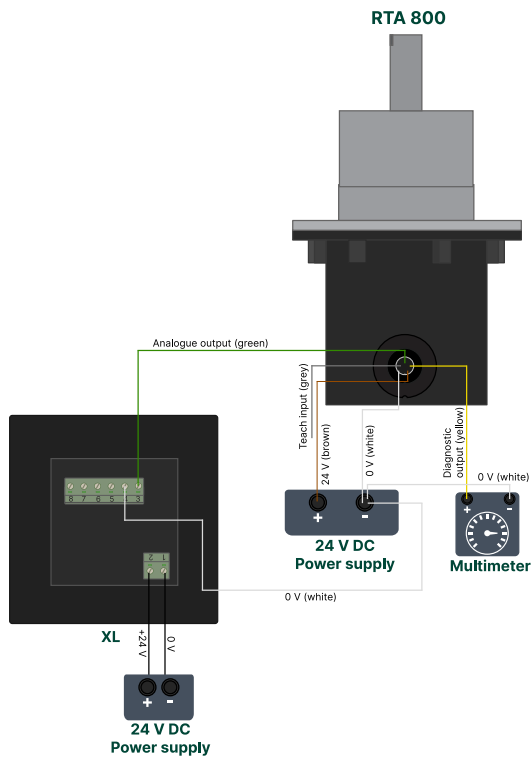

Connect the teach output (yellow wire) to the plus terminal on a multimeter. Connect the negative terminal on the multimeter to the negative terminal on the 24 V DC power supply used for the RTA 800.

Disconnect the teach input (grey wire) from the power supply and then turn on the power supply for the XL and the power supply for the rudder transmitter.

4.

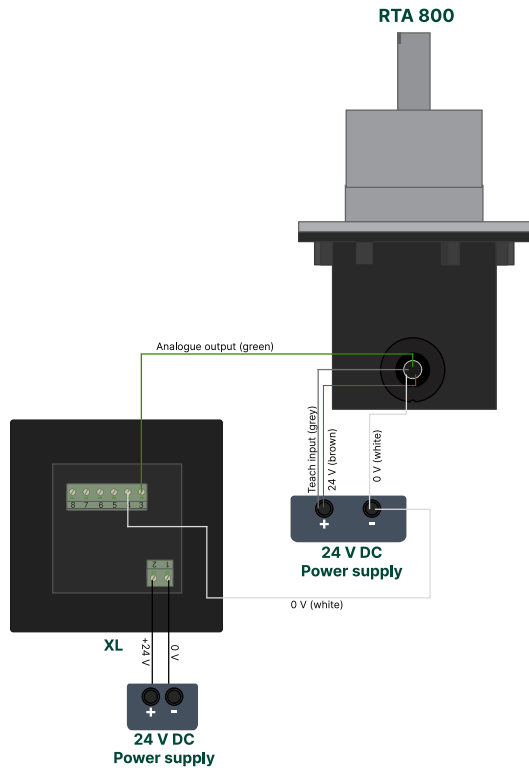

To activate the teach process, connect the teach input to the power supply for the RTA 800 for 5 seconds and then disconnect.

The multimeter starts to oscillate after five seconds, which indicates that the teach process is active.

5.

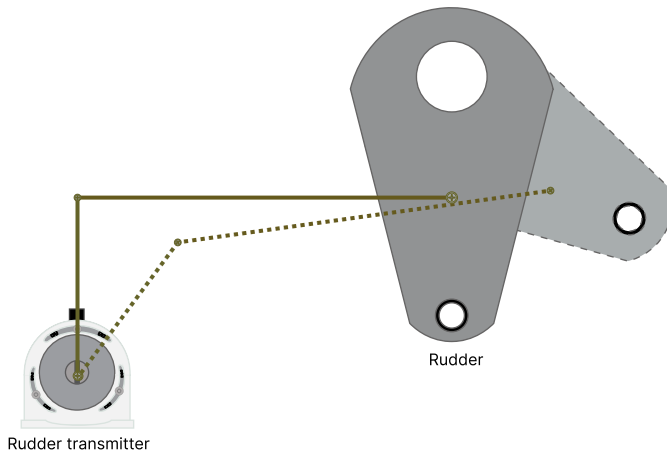

To calibrate the minimum angle, move the rudder into its minimum position.

6.

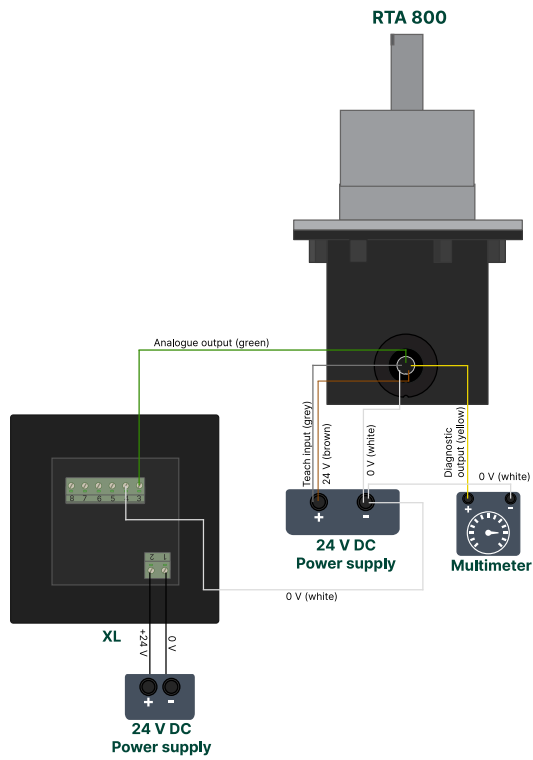

Connect the teach input to the power supply for more than 1 second and then disconnect.

The multimeter displays a high voltage (approximately 20 to 24 V) for approximately 3 seconds and oscillates briefly.

7.

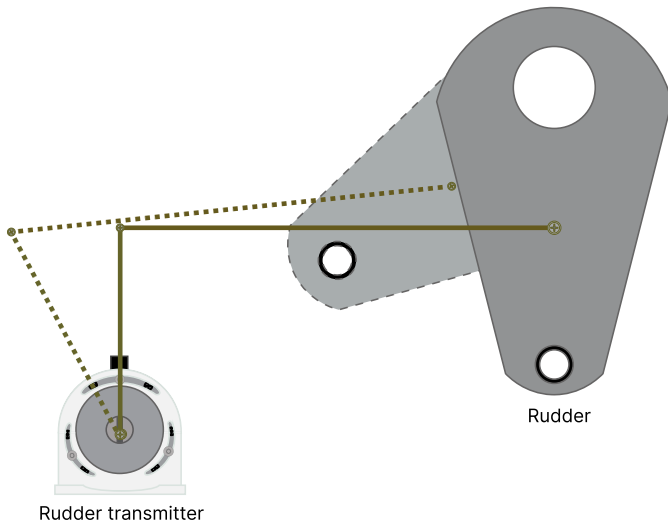

To calibrate the maximum angle, move the rudder into its maximum position.

8.

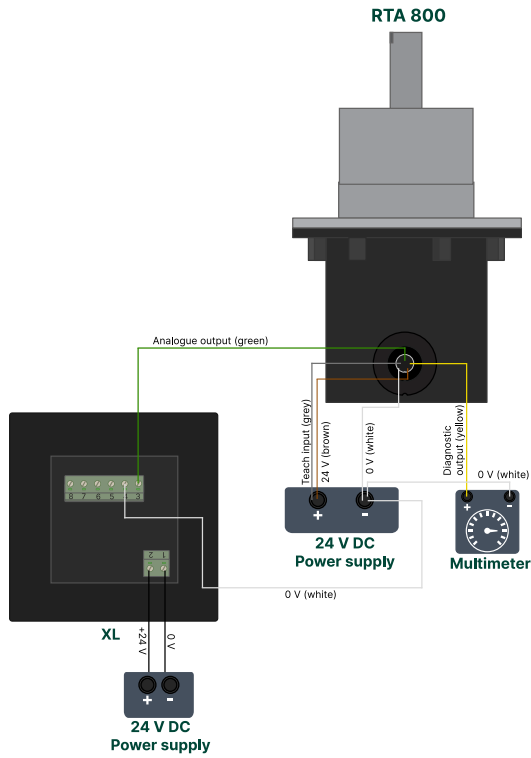

Connect the teach input to the power supply for more than 1 second and then disconnect.

The multimeter displays a high voltage (approximately 20 to 24 V) for approximately 3 seconds and oscillates briefly.

If the measuring range is exceeded or the minimum and maximum positions are too close to each other, the calibration was not successful. You then need to repeat the calibration process.

9.

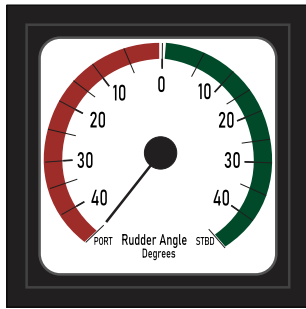

Move the rudder to its minimum position and verify that the XL displays the correct value.

10.

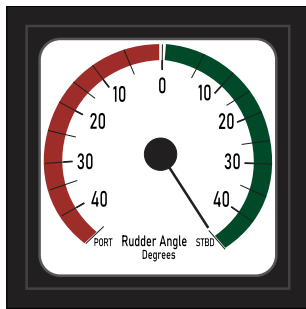

Move the rudder to its maximum position and verify that the XL displays the correct value.

You can also calibrate the RTA 800 mechanically or using the XDi.

### NOTICE



#### Calibration wires from the RTA 800

Make sure you insulate and terminate the calibration wires from the RTA 800 after calibrating the transmitter.

## 4.2 CAN rudder transmitter

You need to calibrate the zero, minimum and maximum angle values after installation of the rudder transmitter. This is to make sure that the port and starboard movements of the rudder are displayed correctly on the rudder indicator.

For the RTC 800, the XL sCAN version is used for the calibration. The NODE-ID for the rudder transmitter must be the same as the CAN-ID for the XL.

**NOTE** If power is lost during the calibration process, you must restart the calibration process as a power loss can cause an incorrect calibration setup.

1.

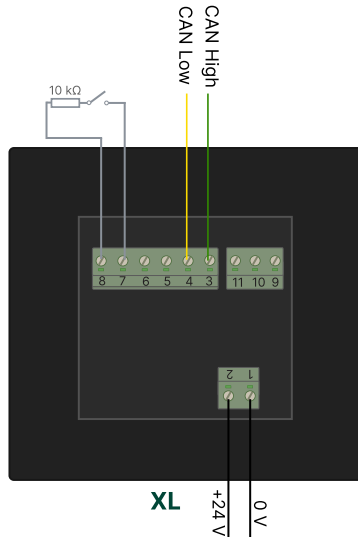

On the XL, connect terminal 7 to terminal 8 via an external switch and through a 10 kΩ resistor.

The set-up switch is used to calibrate the RTC 800.

- Do not close the switch for the first 30 seconds after power-up. If you do close the switch, restart the controller with an open switch.
- To save the calibration settings, the switch must be closed for more than 5 seconds.
- If the switch is closed for more than 20 seconds, the calibration process is terminated and the calibration settings are not saved. You can start the calibration step again by opening the switch for more than 5 seconds.

2.

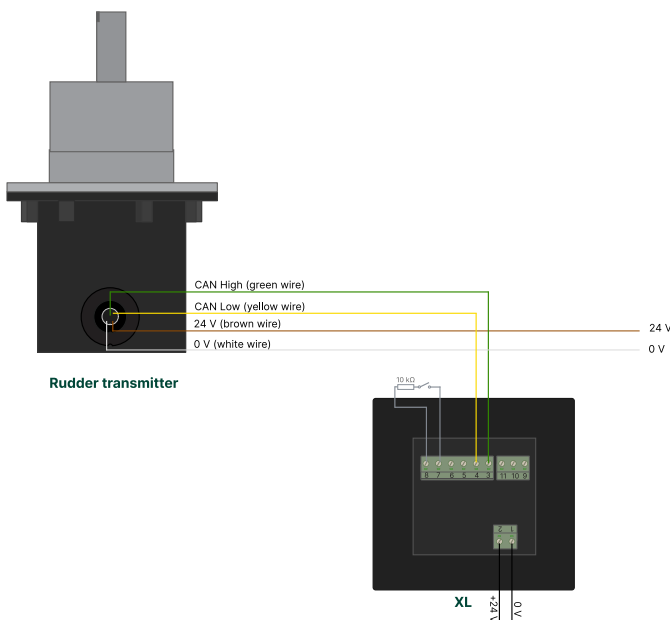

Connect the RTC 800 to the XL as shown in the diagram.

Turn on the XL. After power-up, the LED on the XL flashes once every second until a valid CAN signal is detected. Then the LED turns off.

3.

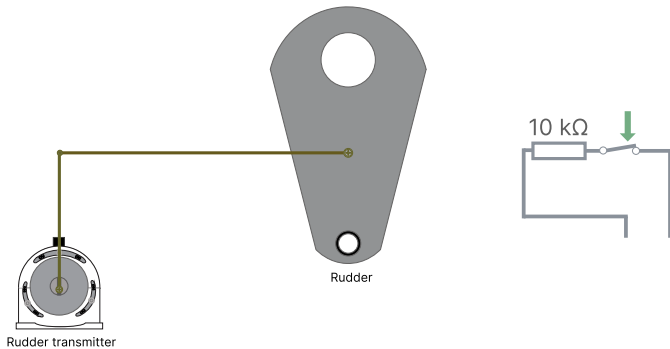

Place the rudder transmitter at the physical zero position and close the switch.

4.

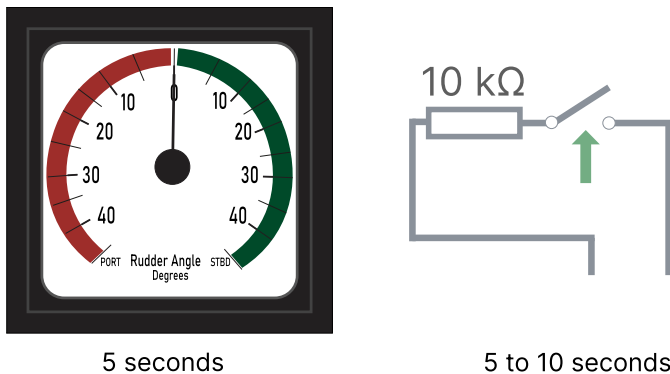

After 5 seconds, the pointer on the XL moves to zero degrees.

Open the set-up switch to store the new zero value. The switch must be opened between 5 and 10 seconds after you first closed the switch. The LED on the XL flashes amber once to verify that the new value has been stored.

If no new value was stored (the switch is still closed), wait for more than 20 seconds with the switch still closed. The calibration process is then terminated without storing the new zero value and the indicator pointer moves back to the scale position given by the rudder transmitter value (normal mode).

5.

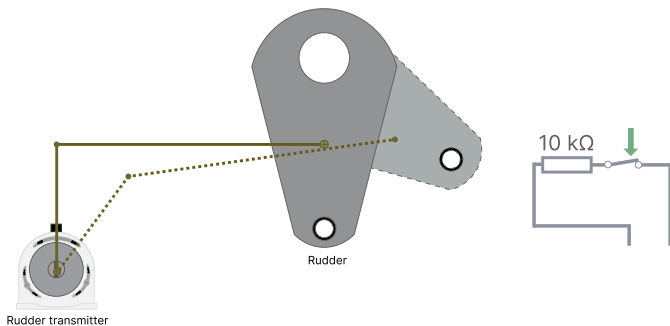

To set the minimum value, place the rudder transmitter at the minimum position and close the set-up switch on the XL.

6.

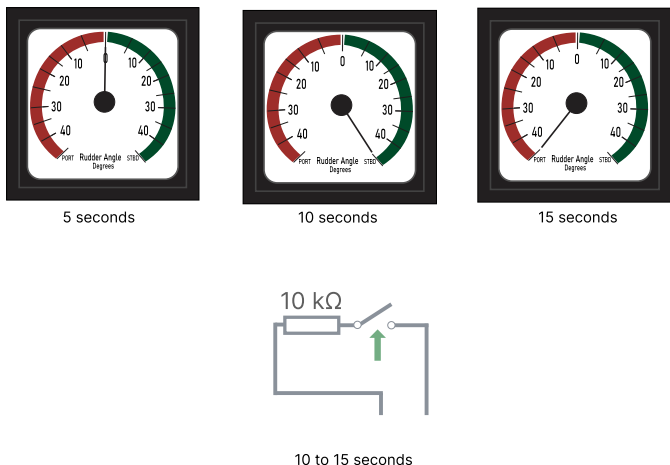

- After 5 seconds, the indicator pointer moves to scale zero.
- After 10 seconds, the pointer moves to the maximum scale value.
- After 15 seconds, the pointer moves to the minimum scale value.

Open the set-up switch to store the new minimum value. The switch must be opened between 10 and 15 seconds after you first closed the switch. The LED on the XL flashes amber once to verify that the new value has been stored.

If no new value was stored, wait for more than 20 seconds with the switch still closed. The calibration process is then terminated without storing the new zero value.

7.

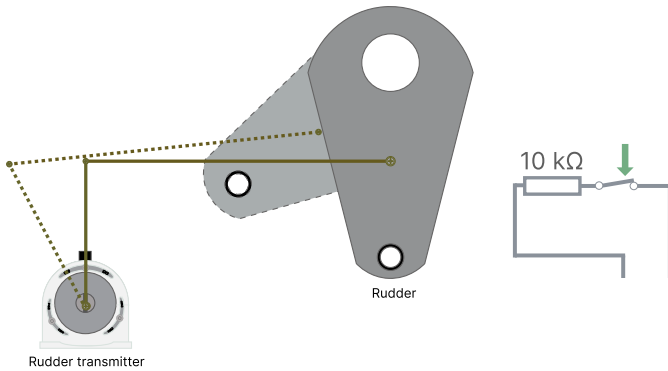

To set the maximum value, place the rudder transmitter at the maximum position and make sure the set-up switch on the XL is closed.

8.

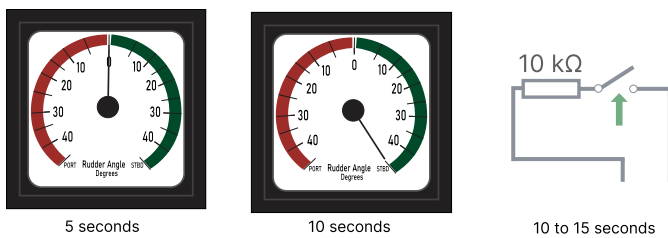

- After 5 seconds, the indicator pointer moves to zero degrees.
- After 10 seconds, the indicator pointer moves to the maximum scale value.

Open the set-up switch to store the new maximum value. The switch must be opened between 10 and 15 seconds after you first closed the switch. The LED on the XL flashes amber once to verify that the new value has been stored.

If no new value was stored, wait for more than 20 seconds with the switch still closed. The calibration process is then terminated without storing the new zero value.

You can also calibrate the RTA 800 mechanically or using the XDi.

#### 4.2.1 Synchronise XL indicators over CAN

XL indicators that are connected through CAN and have the same CAN-ID automatically synchronise with the XL used for the calibration process. Make sure all XL indicators in the system are turned on before you begin the calibration process.

## 5. End-of-life

### 5.1 Disposal of waste electrical and electronic equipment

WEEE symbol



All products that are marked with the crossed-out wheeled bin (the WEEE symbol) are electrical and electronic equipment (EEE). EEE contains materials, components and substances that can be dangerous and harmful to people's health and to the environment. Waste electrical and electronic equipment (WEEE) must therefore be disposed of properly. In the EU, the disposal of WEEE is governed by the WEEE directive issued by the European Parliament. DEIF complies with this directive.

You must not dispose of WEEE as unsorted municipal waste. Instead, WEEE must be collected separately, to minimise the load on the environment, and to improve the opportunities to recycle, reuse and/or recover the WEEE. In the EU, local governments are responsible for facilities to receive WEEE. If you need more information on how to dispose of DEIF WEEE, please contact DEIF.