

RTA 800 and RTC 800

4921250081-E

Rudder angle transmitters

Data sheet

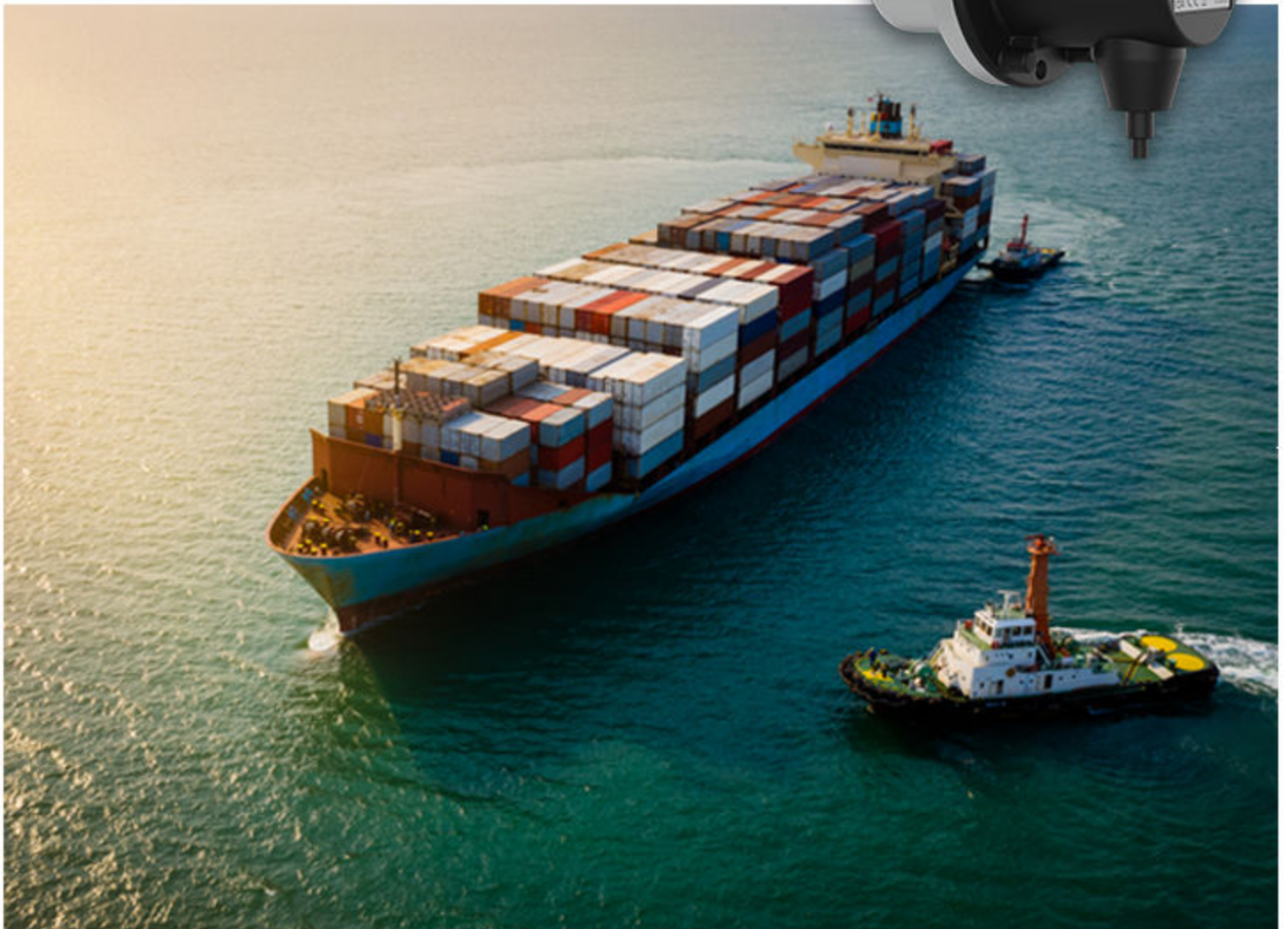

1. RTA 800 and RTC 800

1.1 About the rudder angle transmitters.....	3
1.2 Functions and features.....	3
1.2.1 General functions.....	3
1.2.2 CAN functions.....	3
1.2.3 Analogue functions.....	3

2. Technical specifications

2.1 Dimensions.....	4
2.2 Mechanical specifications.....	5
2.3 Environmental specifications.....	5
2.4 Electrical specifications.....	5
2.5 Azimuth system.....	6
2.6 Approvals.....	6

3. Ordering

3.1 RTA 800 and RTC 800.....	7
3.2 Order specifications.....	7

4. Legal information

5. End-of-life

1. RTA 800 and RTC 800

1.1 About the rudder angle transmitters

The rudder angle transmitters are robust angle sensors designed for marine applications, such as high accuracy rudder, azimuth or pitch angle measurements. The RTA 800 and RTC 800 have high resistance to shock and vibrations, and are protected against corrosion.

The rudder angle transmitter is available in two versions:

- RTA 800: analogue rudder transmitter
- RTC 800: rudder transmitter with a CAN interface that supports CANopen

1.2 Functions and features

1.2.1 General functions

General functions

Single-turn encoder

Mechanical and electrical backward compatibility with previous RTA and RTC 600 series transmitters from DEIF

1.2.2 CAN functions

CAN functions

Precise calibration with CAN

Electronic gear function

Operating modes:

- Timer driven (event time)
- Synchronously triggered (sync)

Node monitoring:

- Heart beat
- Node guarding

Configurable parameters, for example, total resolution and scaling

Diagnosis function:

- Position error
- Exceeding temperature and speed range

1.2.3 Analogue functions

Analogue functions

Precise calibration with wire

2. Technical specifications

2.1 Dimensions

Dimensions without a bracket

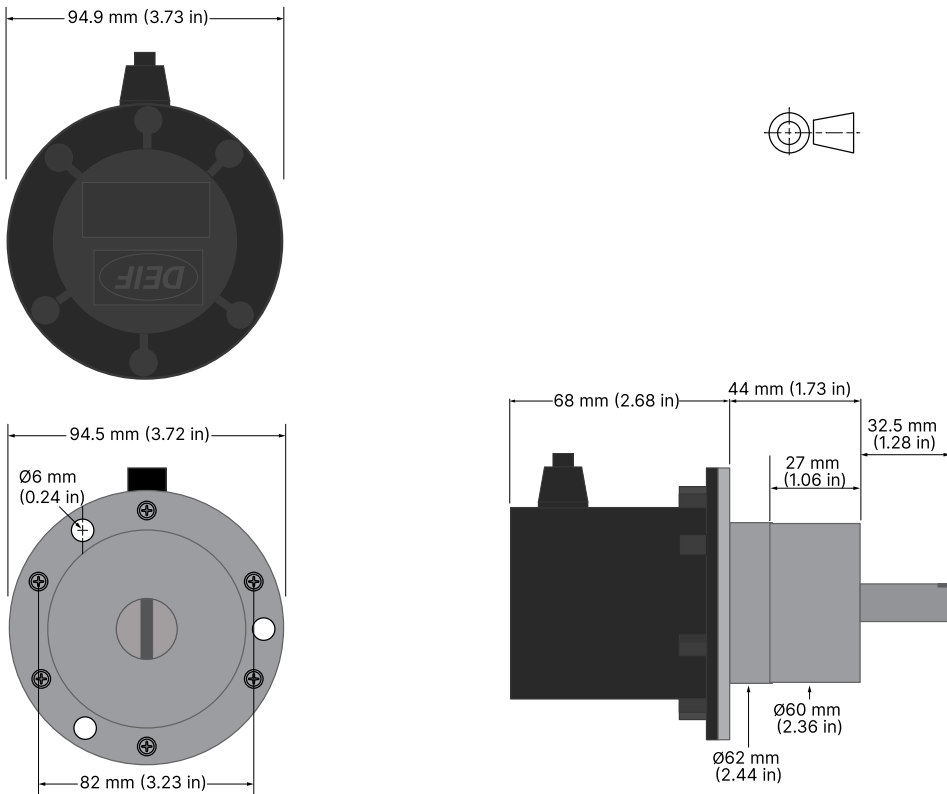

Dimensions with the bracket from DEIF

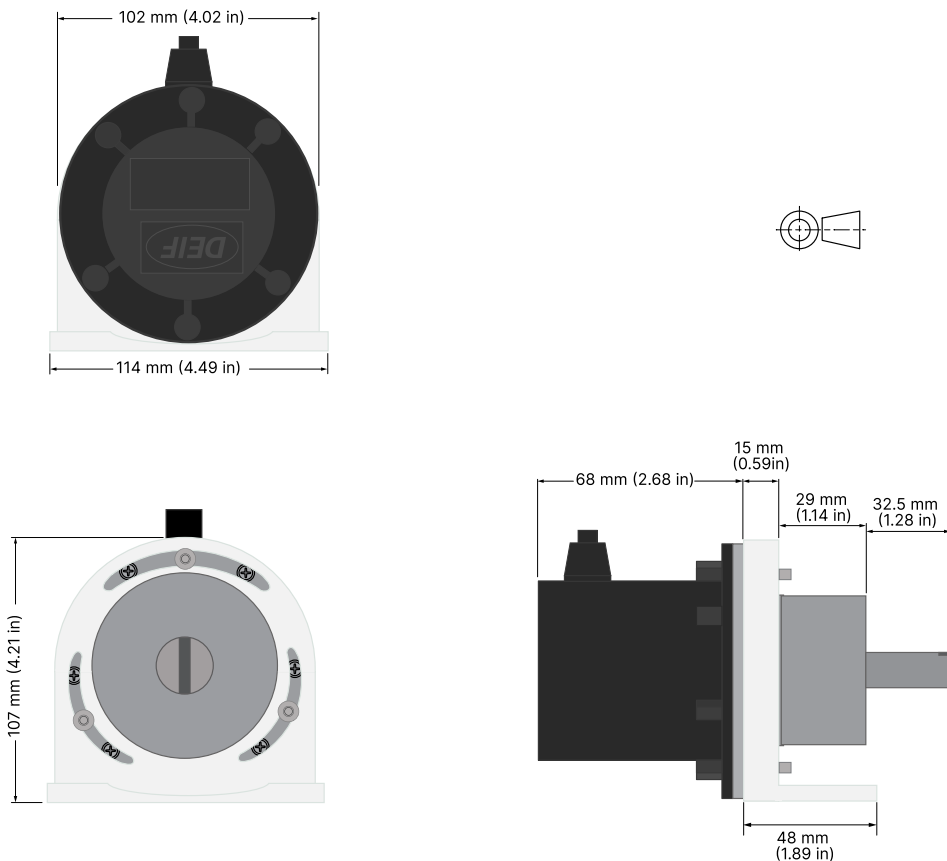

Weight

Rudder transmitter with bracket	964 g
Rudder transmitter without bracket	653 g

NOTE The cable from the transmitter is 2 m 5 x 0.5 mm².

2.2 Mechanical specifications

Operation conditions	RTA 800 and RTC 800
Starting torque	Less than or equal to 0.25 Nm
Shaft load	Axial: 500 N Radial: 1000 N
Vibration	3 to 13.2 Hz: 2 mm (peak-peak) 13.2 to 100 Hz: 0.7 g DNV, Class A EN/IEC 60945 EN/IEC 60068-2-6
Shock	50 g, half sine, 11 ms
EMC	DNV, Class A EN/IEC 60945
Insulation	600 V AC, 50 Hz, 60 seconds EN 61010-1
Material	Housing: anodised aluminium and GF30 polyamide Shaft: stainless steel Bracket: stainless steel

2.3 Environmental specifications

Operation conditions	RTA 800 and RTC 800
Operating temperature	-40 to +85 °C
Protection degree	DNV, Class A IEC/EN 60945 • IP65

2.4 Electrical specifications

Electrical specifications	RTA 800	RTC 800
Voltage supply	14 to 30 V DC *	10 to 30 V DC *
Load resistance	Maximum 500 Ω	-
Consumption type	20 mA (24 V DC, without load)	20 mA (24 V DC, without load)
Reverse polarity protection for the power supply	Yes	Yes
Initialising time	Less than or equal to 170 ms after power on	Less than or equal to 170 ms after power on
Response time	less than 1 ms	-
Steps per revolution	-	Less than or equal to 16384/14 bit
Number of revolutions	-	Less than or equal to 262144/18 bit

Electrical specifications	RTA 800	RTC 800
Absolute accuracy	±0.15 degrees (+ 20 ±15 °C) ±0.25 degrees (-40 to +85 °C)	±0.15 degrees (+ 20 ±15 °C) ±0.25 degrees (-40 to +85 °C)
Accuracy of analogue output	±0.5 % of the entire measuring range (-40 to +85 °C)	-
Sensing method	Magnetic	Magnetic
Code sequence	-	Clockwise (CW): increasing values in clockwise rotational direction when looking at the flange
Outputs	-	CAN bus, low voltage (LV) 3.3 V compatible. To ISO 11898
Interface	Analogue 4 to 20 mA Resolution: 12 bit	CANopen
Function	Single turn	Single turn
Teach range	5 degrees to 359.9 degrees	-
Conformity	-	CANopen CiA communication profile DS 301 LSS profile DSP 305 Device profile DS 406
Connection	2 m 5 x 0.5 mm ² cable	2 m 5 x 0.5 mm ² cable

NOTE *Voltages above 36 V DC may damage the sensor.

2.5 Azimuth system

Both the CAN and analogue rudder transmitter can be used in an Azimuth system, but we recommend that you use the RTC 800 CAN rudder transmitter for this type of system.

For more detailed information on how to use the DEIF angle transmitters and illuminated indicators in rudder or azimuth applications, go to www.deif.com to find the relevant application notes.

2.6 Approvals

Standards

Refer to www.deif.com for the most recent approvals.

3. Ordering

3.1 RTA 800 and RTC 800

Type	Item number	Variant number	Description
RTA 800	2951860010	06	Rudder transmitter Analogue
RTC 800	2951860010	07	Rudder transmitter CAN

Available accessories

Item	Item number	Variant number	Description
Adjustable lever	291299009	01	Adjustable lever with a maximum length of 1127 mm.
Position linkage	291299009	02	Position linkage with a length of 317 mm.
90° bracket	2195350001		90 degree mounting bracket
IP66 connection box	2912990115	05	IP66 connection box for use with DEIF wind sensors. Watertight connection between the extension cable and the pigtail cable from the wind sensor.

3.2 Order specifications

Variants

Mandatory information			Additional options to the standard variant		
Item no.	Type	Variant no.	Option	Option	Option

Accessories

Mandatory information		
Item no.	Variant no.	Accessory

4. Legal information

Disclaimer

DEIF A/S reserves the right to change any of the contents of this document without prior notice.

The English version of this document always contains the most recent and up-to-date information about the product. DEIF does not take responsibility for the accuracy of translations, and translations might not be updated at the same time as the English document. If there is a discrepancy, the English version prevails.

Copyright

© Copyright DEIF A/S. All rights reserved.

5. End-of-life

Disposal of waste electrical and electronic equipment

WEEE symbol



All products that are marked with the crossed-out wheeled bin (the WEEE symbol) are electrical and electronic equipment (EEE). EEE contains materials, components and substances that can be dangerous and harmful to people's health and to the environment. Waste electrical and electronic equipment (WEEE) must therefore be disposed of properly. In the EU, the disposal of WEEE is governed by the WEEE directive issued by the European Parliament. DEIF complies with this directive.

You must not dispose of WEEE as unsorted municipal waste. Instead, WEEE must be collected separately, to minimise the load on the environment, and to improve the opportunities to recycle, reuse and/or recover the WEEE. In the EU, local governments are responsible for facilities to receive WEEE. If you need more information on how to dispose of DEIF WEEE, please contact DEIF.